



**Product ID: 800-BATT05**  
**110V 40A Train Charger**  
**User Manual**



**Contact Details**

|           |   |
|-----------|---|
| Telephone | +44 (0) 1509 230100   |
| Address   | Flotec Industrial Limited<br>Unit 8, Pavilion Way, Loughborough,<br>Leicestershire LE11 5GW<br>United Kingdom |
| E-mail    | <a href="mailto:rail@flocetonline.com">rail@flocetonline.com</a>  |
| Website   | <a href="http://bit.ly/train-battery-charging">http://bit.ly/train-battery-charging</a>                       |

## CONTENTS

|     |                              |   |
|-----|------------------------------|---|
| 1   | SAFETY.....                  | 3 |
| 2   | GENERAL DESCRIPTION .....    | 4 |
| 3   | SPECIFICATION.....           | 5 |
| 4   | OPERATION.....               | 6 |
| 4.1 | ALARMS .....                 | 7 |
| 5   | TROUBLESHOOTING .....        | 8 |
| 6   | RECOMMENDED MAINTENANCE..... | 9 |

# 1 Safety



Please read this section carefully as the equipment contains lethal voltages and a high amount of stored energy and operating the equipment correctly will reduce the operating danger.

## Qualified Personnel



Due to the high voltages and high energy levels present in the equipment, use only appropriately qualified personnel to install, maintain and repair this equipment. Personal jewellery such as bracelets and necklaces should always be avoided.

## Correct Tools



Whenever possible use insulated tools. Use the correct tool for the job. A poorly crimped connection can lead to the equipment being damaged or even fire in an extreme case.

## High Voltage



The equipment is powered by 415V AC supply. Isolate the equipment before working on it and use appropriate procedures. Do not attempt to repair the unit. Return any faulty equipment to Flotec for repair.

## High Energy



Both the power supply and the batteries possess a large amount of stored energy. A short circuit or incorrect battery fusing could deliver a very high current, enough to melt tools or jewellery. Take care when working on the equipment, even the low voltage DC circuit.

## Handling



The system contains sensitive electronic equipment. Packaging is provided for transportation, always transport the equipment in it. If the equipment is dropped return it to Flotec for inspection and re-test.

## Environment



Electronic equipment should be stored in a dry temperature-controlled environment. When installing the equipment, ensure that it is not too cold such that it causes condensation.

Always operate the equipment in the driest and coolest conditions as possible as this will maximise component life and equipment safety.

## Conductor Sizing



Always use the correct size cable rating. Apart from producing high voltage drops and a risk to system integrity, a cable of too low a rating can cause a fire hazard.

Crimps are made for cables of a certain size; do not use a cable outside the recommended range.

## 2 General Description

The 800-BATT05 is a portable battery charger designed to charge 110V (nominal) train batteries up to 40A. Its output voltage is selectable for either Gel or Wet cell batteries and its output current is 40A. The output cable is supplied with short adapter cables to match train connectors, allowing for more lightweight solution and easier handling. The charger is mounted to a trolley for mobility and cable storage. Wall-mounting brackets are available as an option. It is designed to be splash-proof and operate at full-load in ambient temperatures of up to 45°C.

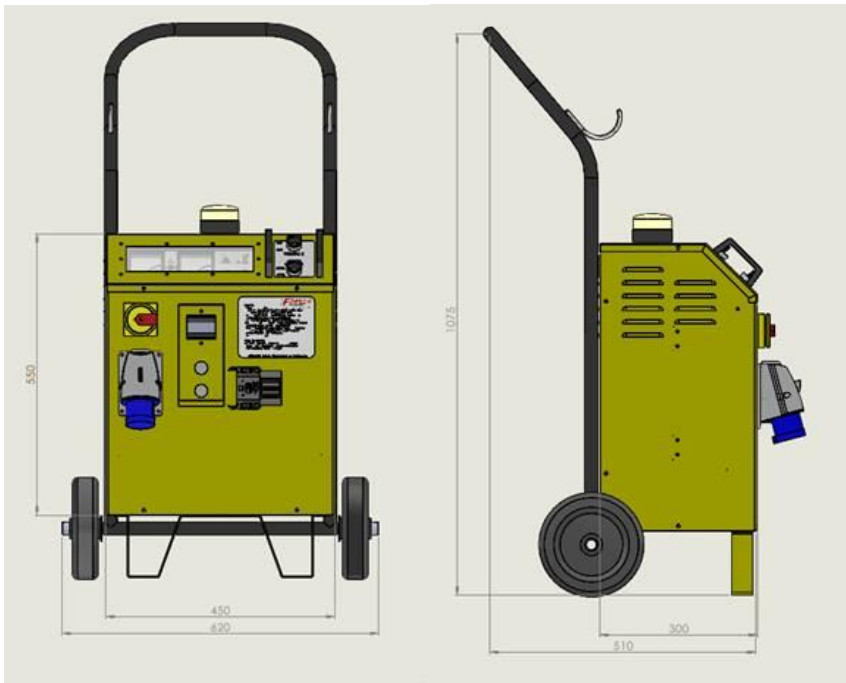

### **3 Specification**

#### **Input:**

Voltage 415 Volt 32 Amp  
Frequency 47-63 Hz  $\pm 5\%$   
Current 30A at 415VAC

#### **Output:**

Voltage 110V  
Current 40A  
Regulation load & line  $\pm 1\%$   
Output ripple  $< 300\text{mVp-p}$   
Efficiency  $> 90\%$

#### **Protection:**

Input 32A MCB  
Output protection OVP, OLP, OTP, SCP, Fan Fail

#### **Environment:**

Temperature  $-15^{\circ}\text{C}$  to  $+45^{\circ}\text{C}$  operating  
Humidity 20 to 90% RH, non-condensing  
Ingress protection IP23 (rain resistant)  
Safety EN60950  
EMC EN55022, EN61204-3, EN61000-6-3  
EN55024, EN61000-6-1, EN61000-4-2, 3-6, 8, 11

#### **Mechanical**

Charger dimensions 490mm W x 300mm D x 550mm H  
Trolley dimensions 620mm W x 510mm D x 1090mm H  
Weight  $< 40\text{kg}$

## 4 Operation

Ensure the charger is placed on a flat stable surface.

1. CONNECT input and output cables.
2. Turn ON main power isolator. Red AC ON indicator should illuminate.
3. Turn CURRENT selector to appropriate setting until corresponding green indicator illuminates (approx. 1sec).
4. CHARGING is indicated by STEADY illumination of the top-mounted beacon. Digital meters display output voltage and charging current.
5. CHARGE COMPLETE (<10A) is indicated by a SLOW BLINK of the beacon.
6. An ALARM condition is indicated by a FAST FLASH of the beacon and illumination of the red ALARM indicator. See section 8 – Troubleshooting.

To RESET:

1. Turn BOTH voltage and current selector switches simultaneously to any position for approximately 1sec. Output will be disabled and corresponding indicators will extinguish.

**Note<sup>1</sup>:** If the batteries have a high level of charge, then the charge current maybe be less than the “Charged” threshold and the top-mounted beacon will indicate this with a slow blink. The current meter is for indication only and will not accurately show small currents less than the 10A “charged” threshold. Batteries will continue to pull minimal charge current.

**Note<sup>2</sup>:** The top-mounted beacon will indicate an alarm condition when the batteries become disconnected for any reason whilst charging is enabled. Follow the RESET procedure above to stop the alarm.

Refer to sections 4.1 and 5.

## 4.1 Alarms

The top-mounted beacon will indicate an alarm condition when the batteries become disconnected for any reason whilst charging is enabled. The alarm can also be triggered by any of the internal error states:

- Over-voltage
- Over-load
- Over-temperature
- Fan-fail

**Note<sup>3</sup>:** A persistent alarm condition indicates a problem and should be investigated by appropriately trained personnel. See section 5 - Troubleshooting, below.

## 5 Troubleshooting

| Not charging   | Possible remedy   |
|--|---|
| No power - no indicators or meters are lit with input isolator in the ON position.   | Check front panel MCB (behind protective cover in front recess) is ON. Check mains supply connectors, cables and breakers.  |
| No charge current indicated and beacon is blinking slowly.   | Batteries are already charged. Minimal current being delivered.   |
| Alarm (possible causes)  | Possible remedy   |
| Batteries disconnected after charging cycle has begun.   | Check both charger and train connections, fuses, breakers etc.<br>Check battery has not been isolated.<br>Any time-release contactors in operation?                                     |
| Connected load is trying to pull more current than charger is rated for.   | Double-check ratings and connections. Compare operation with a known-good train if possible.  |
| Internal temperature is too high.<br>Ambient temperature is too high.<br>One or more of the internal cooling fans have failed. | Allow to cool and ensure vents are clear from any build-up of dust and grime.<br>Dust and grime can prevent fans from functioning. See section 6 - Recommended Maintenance <sup>1</sup> |
| Over-voltage protection - Output voltage is measured to be higher than the controlled value.                                   | Connected to wrong battery type or internal fault.  |
| If problem persists, contact supplier for investigation and repair.  |   |

---

<sup>1</sup> If compressed air is used to clear dust, care must be taken to ensure fans are not allowed to spin. Fast spinning fans could generate potentially damaging voltages to internal components or exceed their max speed causing mechanical damage.



## **6 Recommended Maintenance**

The charger is designed to be as low-maintenance as possible, but the following activities should be observed:

- Periodically (depending on duration and conditions of operation), inspect condition of all input and output cables, connectors, switches and indicators for signs of degradation that may impact safety or functionality.
- Periodically (again, depending on duration and conditions), ensure all cooling vents are free from dust and grime build up. Monitor and clean as required.
- Annually, apply a few drops of medium oil to the trolley wheel-axle interface.